



Product Specifications

Li-ion Battery Pack Specification

MODEL

18650-3350mAh-1S6P

Nominal Capacity

20.1Ah

Customer

Registered	Checked	Approved
2020.05.11		2020.05.11

Customer Approve		
Dept.	Signature	Date
QA Dept		
R&D Dept		
Approved		

Content

1.MODIFIED LIST	3
2 .Scope	3
3.Battery pack parameters	4
3.1 Battery pack assembly drawing and dimension drawing	4
3.2 Battery pack basic technical parameters.....	5
3.3 Battery pack constitute List	5
4.Battery Cell type and parameters.....	6
4.1. Battery Cell model/capacity.....	6
4.2. Battery Cell outline dimension drawing	6
4.3 Battery Cell basic technical parameters	7
5.PCB parameters	8
5.1Application range	8
5.2PCB appearance and process indicators.....	8
5.3PCB List of main components	8
5.4PCB electrical performance indicators	9
5.5Electrical schematic diagram	9
5.6Outline dimension and PCB board drawing	10
5.7Port description	10
6.CAUTIONS IN USE	11
7.Battery operation instruction	11
7.1 Charging.....	11
7.2 Discharging current.....	12
7.3 discharge temperature	12
7.4 Over-discharges	12
7.5 Storing the Batteries	12
8.Period of Warranty	12
9.Other The Chemical Reaction	13
10.Note:	13

1.MODIFIED LIST

Product Modified Record List

Revision	Date	Mark	Modified content	Approved by
A1				

2 .Scope

This specification describes the basic performance, technical requirement, testing method, warning and caution of the Li- ion Cylindrical rechargeable battery or battery pack.The specification only applies to ShenZhen IZM New energy co.,LTD

3. Battery pack parameters

3.1 Battery pack assembly drawing and dimension drawing

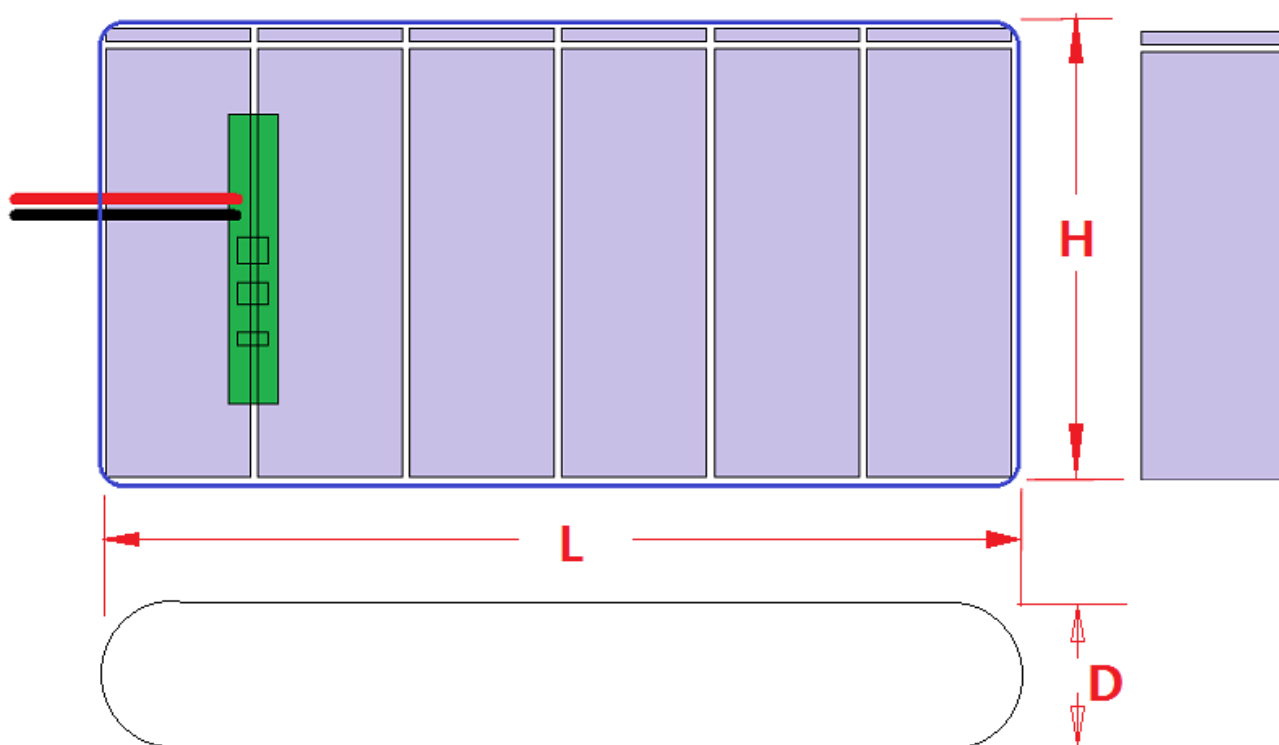

Item	Description	Size
L	The max Size	111.0mm
H	The max Size	66.0mm
D	The max Size	19.0mm
	Wire type and Length	According to the requirements
Connector type and sequence		According to the requirements 际要求

3.2 Battery pack basic technical parameters

NO.	Item	Specifications
1	Typical Capacity	20.1Ah @ 0.2C Discharge
	Minimum capacity	19.5Ah @0.2C Discharge
2	Nominal voltage	3.6V
3	Standard Charge	CC/CV, \approx 2.0A, 4.20V Full
4	Max charge current	CC/CV, \approx 5.0A, 4.20V Full
5	Charging Time	\approx 11hours (standard charge) (5V-2A)
6	End-of-charge Voltage	4.25 \pm 0.05V
7	End-of-charge Current	0.01C \approx 0.20A (At CV mode)
8	Standard Discharge	0~5.0A
9	Max Discharge Current	6.5A (PCB biggest discharge)
10	Initial Impedance	Approx:65m Ω
11	Weight	Approx: 290 \pm 5g
12	Operating temperature	Charging: 0 $^{\circ}$ C~+45 $^{\circ}$ C Discharging: -10 $^{\circ}$ C~+50 $^{\circ}$ C
13	Storage temperature	-20 $^{\circ}$ C~50 $^{\circ}$ C (1month) ; -20 $^{\circ}$ C~45 $^{\circ}$ C (3month) ; -20 $^{\circ}$ C~20 $^{\circ}$ C (12month)
14	Standard environmental condition	Temperature : 23 \pm 5 $^{\circ}$ C Humidity : 45-75%RH Atmospheric Pressure : 86-106 KPA

3.3 Battery pack constitute List

NO.	Name	List	Unit	Number	Note
1	Battery cell	18650-3350mAh	PCS	6	
2	PCB protection board	3.7vPCB	PCS	1	
3	wire	22#100mm	PCS	1	
4	label	PET	PCS	1	
5	other material				

4. Battery Cell type and parameters

4.1. Battery Cell model/capacity:

GZNS18650-3350mAh

4.2. Battery Cell outline dimension drawing:

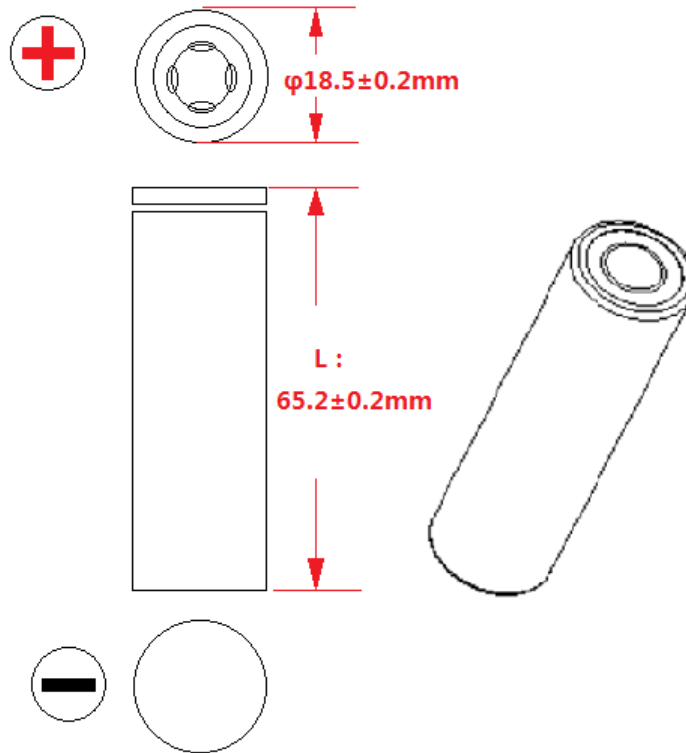

4.3 Battery Cell basic technical parameters

NO.	Item	Specifications
1	Typical Capacity	3350mAh @ 0.2C Discharge
	Minimum capacity	3250mAh @0.2C Discharge
2	Nominal voltage	3.6V
3	Standard Charge	CC/CV, $\approx 0.3C$ 1.005A, 4.20V Full
4	Quick Charge Current	CC/CV, $\approx 0.5C$ 1.675A, 4.20V Full
5	Max charge current	CC/CV, $\approx 0.75C$ 2.50A, 4.20V Full
6	Charging Time	≈ 4.5 hours (standard charge) (5V-1A)
7	End-of-charge Voltage	4.25 \pm 0.05V
8	End-of-charge Current	0.01C \approx 0.0335A (At CV mode)
9	Standard Discharge	0.5C,1675mA
10	Quick Discharge Current	1.0C,3350mA
11	Max Discharge Current	6700mA
12	Initial Impedance	Approx:35m Ω
13	Weight	Approx: 46 \pm 2g
14	Operating temperature	Charging: 0 $^{\circ}$ C~+45 $^{\circ}$ C Discharging: -10 $^{\circ}$ C~+50 $^{\circ}$ C
15	Storage temperature	-20 $^{\circ}$ C~50 $^{\circ}$ C (1month) ; -20 $^{\circ}$ C~45 $^{\circ}$ C (3month) ; -20 $^{\circ}$ C~20 $^{\circ}$ C (12month)
16	Storage Humidity	$\leq 75\%$ RH
17	Appearance	Without scratch, distortion, contamination and leakage
18	Standard environmental condition	Temperature : 23 \pm 5 $^{\circ}$ C Humidity : 45-75%RH Atmospheric Pressure : 86-106 KPA
19	Cycle Life	≥ 500 times(次)
20	Discharge at high temperature	$\leq +60^{\circ}$ C
21	Discharge at low temperature	$\geq -20^{\circ}$ C

5.PCB parameters

5.1 Application range

- (1) Liquid lithium ion rechargeable battery
- (2) Polymer lithium ion rechargeable battery

5.2 PCB appearance and process indicators

NO.	Item	Inspection Methods	Inspection standard
1	Product appearance	observe	The wiring is reasonable, the components are arranged neatly, the pads and welding spots are free from oxidation, no color abnormality, the components and PCB board surface is clean, no stains, does not affect its commercial value.
2	焊接工艺	Welding process	observe The welding spot is smooth, the welding is firm and reliable, no false welding, false welding, burr and other welding defects.
		Plate material	FR4 Glass fiber double
		PCB Surface process	SMOBC&HAL
		Lead-free solder	Lead-free solder

5.3 PCB List of main components

NO.	Element number	Element name	Element specifications	Packaging form	Number	Note
1	U1	IC	DW01	SOT-23-6	1	
2	U2	MOSFET	8025A	SOT-23-8	1	
3	U3	MOSFET	8025A	SOT-23-8	1	
4	R1	resistance	SMD100Ω ±5%	0603	1	
5	R2	resistance	SMD 1KΩ ±5%	0603	1	
6	R3	resistance	SMD 10KΩ ±5%	0603	0	Spare extension
7	C1	capacitance	0.1μ F-20%/80%	0603	1	
8	PCB	PCB circuit board	(45mm±0.2mm)*(4mm±0.2mm)*0.6mm	--	1	

5.4 PCB electrical performance indicators

T_{opt}=25°C

Item	Symbol	Detailed content	Standard
overcharge protection	VDET1	Overcharge voltage detection	4.25±0.05V
	tVDET1	Overcharge detection delay time	200ms (MAX)
	VREL1	Overcharge release voltage	4.1±0.05V
Over discharge protection	VDET2	Over discharge detection voltage	2.45V±0.1V
	tVDET2	Over discharge detection delay time	60ms (MAX)
	VREL2	Over discharge release voltage	3.0V±0.1V
Over current protection	VDET3	Over current detection voltage	150±30mV
	IDP	Over current protects the current	2.0-6.5A
	tVDET3	Detection delay time	20ms (MAX)
		Protection release condition	Disconnect load
Short circuit protection	TSHORT	Protect conditions	Short circuit
		Detection delay time	50μ s (MAX)
		Protection release condition	Break the short circuit
Internal resistance	RDS	Main circuit on resistance	RDS≤60mΩ
Consumption, current	IDD	Internal circuit consumption during operation	2.0-6.0uA

5.5 Electrical schematic diagram

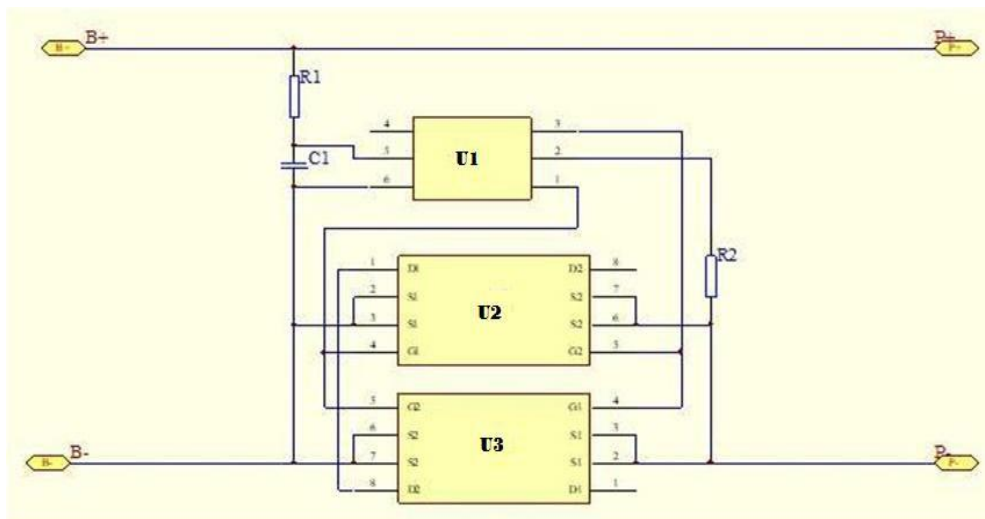

5.6 Outline dimension and PCB board drawing

Top :

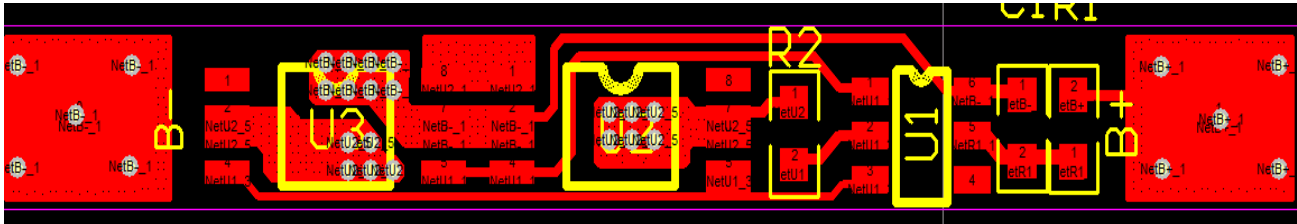

Low :

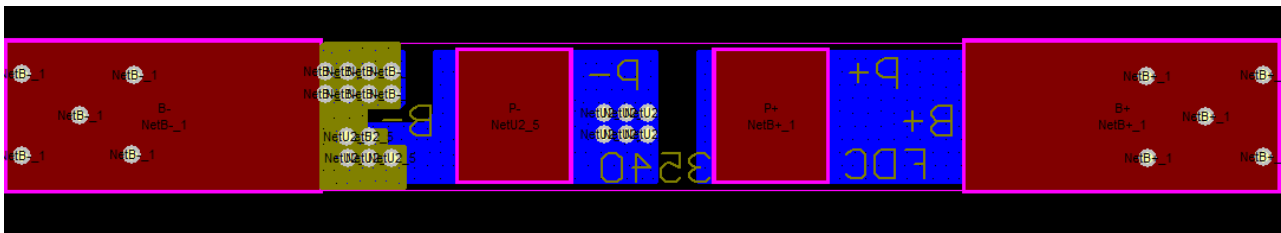

Real figure :



5.7 Port description

- (1) B+: Connect the positive terminal of the cell
- (2) B-: Connect the negative terminal of the cell
- (3) P+: Connect the battery pack output terminal or the positive terminal of the charger
- (4) P-: Connect the battery output terminal or the negative terminal of the charger

6. CAUTIONS IN USE

To ensure proper use of the battery please read the manual carefully before using it. Handling

- Do not expose to, dispose of the battery in fire.
- Do not put the battery in a charger or equipment with wrong terminals connected.
- Avoid shorting the battery
- Avoid excessive physical shock or vibration.
- Do not disassemble or deform the battery.
- Do not immerse in water.
- Do not use the battery mixed with other different make, type, or model batteries.
- Keep out of the reach of children.
- **charge and discharge**
- **Battery must be charged in appropriate charger only.**
- **Never use a modified or damaged charger.**
- **Do not leave battery in charger over 24 hours.**
- . storage
 - **Store the battery in a cool, dry and well-ventilated area.**
- . disposal
 - **Regulations vary for different countries. Dispose of in accordance with local regulations.**

7. Battery operation instruction

7.1 Charging

Charging current: Cannot surpass the biggest charging current which in this specification book stipulated.

Charging voltage: Does not have to surpass the highest amount which in this specification book stipulated to decide the voltage.

Charge temperature: The battery must carry on the charge in the ambient temperature scope which this specification book stipulated.

Uses the constant electric current and the constant voltage way charge, the prohibition reverse charges. If the battery positive electrode and the cathode meet instead, can damage the battery.

7.2 Discharging current

The discharging current does not have to surpass this specification book stipulation the biggest discharging current, the oversized electric current electric discharge can cause the battery capacity play to reduce and to cause the battery heat.

7.3 discharge temperature

The battery discharge must carry on in the ambient temperature scope which this specification book stipulated

7.4 Over-discharges

After the short time excessively discharges charges immediately cannot affect the use, but the long time excessively discharges can cause the battery the performance, battery function losing. The battery long-term has not used, has the possibility to be able to be at because of its automatic flashover characteristic certain excessively discharges the condition, for prevented excessively discharges the occurrence, the battery should maintain the certain electric quantity.

7.5 Storing the Batteries

The battery should store in the product specification book stipulation temperature range. If has surpasses above for six months the long time storage, suggested you should carry on additional charge to the battery.

8. Period of Warranty

The period of warranty is one year from the date of shipment. guarantees to give a replacement in case of cells with defects proven due to manufacturing process instead of the customers abuse and misuse.

9. Other The Chemical Reaction

Because batteries utilize a chemical reaction, battery performance will deteriorate over time even if stored for a long period of time without being used. In addition, if the various usage conditions such as charge, discharge, ambient temperature, etc. are not maintained within the specified ranges the life expectancy of the battery may be shortened or the device in which the battery is used may be damaged by electrolyte leakage. If the batteries cannot maintain a charge for long periods of time, even when they are charged correctly, this may indicate it is time to change the battery.

10.Note:

Any other items which are not covered in this specification shall be agreed by both parties.